

INDUSTRIAL FILTRATION PRODUCTS

CONSLER AGS SERIES AIR & GAS FILTER SEPARATORS

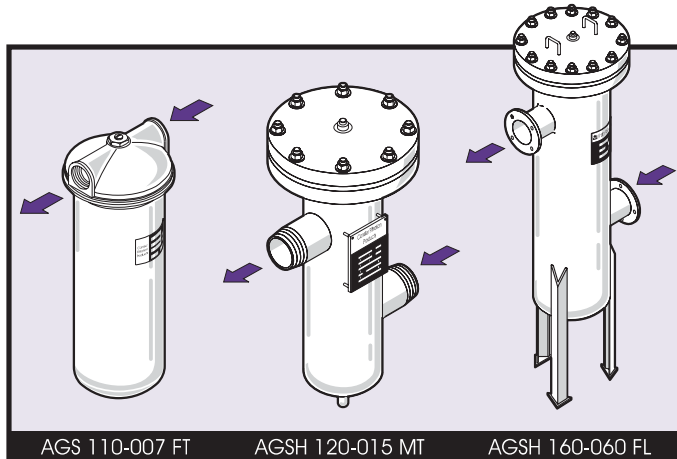

Features

- ASME Code design and constructed
- High flow rate capability
- Low pressure drop & long element life
- High temperature capability
- Economical replaceable cartridges
- Modified and custom designs available
- Design pressures from 180 psi to 1440 psi
- Contact Factory for higher pressure applications

Applications

- Effective separation of oil, water and other liquid Aerosols from compressed air and gas lines.
- High efficiency removal of:
 - Dispersed liquids, .3 & up, 99% minimum efficiency.
 - Solid particles, .3 & up, 99% minimum efficiency.
- Use as a pre-filter to an air dryer, increasing system efficiency and equipment service life.
- Gas pipeline applications; to protect equipment from liquid and solid contaminants.
- Ideal for satisfying OEM specifications.

Element Design & Construction

The AGS Series of coalescing filters offers the use of a unique high efficiency media. The element is constructed of multiple layer pleated fiberglass which is supported on a carbon steel core. The elements are available with stainless steel internals for more corrosive applications. The drainage of coalesced liquids and protection from re-entrainment is provided by a polyester foam outer wrap. The pleated design fiberglass element has extended surface area that leads to high dirt loading and long efficient service life.

The coalescing action is a gathering of minute liquid particles or smaller droplets to form larger droplets. The small droplets that enter the inside of the element are intercepted or impinged

Against the filter media and are extracted from the gas stream. The larger droplets once formed, drain off the outside of the element and fall by gravity to the sump area in the filter housing where a drain connection is provided for removing the coalesced liquid. The high efficiency element prevents re-entrainment of the liquid downstream. The coalescing action continues at the same rate that new liquid enters the element, allowing long service life before element replacement is required.

The cartridge is designed with an inside diameter that is approximately the same dimension as the inlet and outlet. This unique design allows for a smooth transition of the flow through the housings and elements. The net result is a low pressure drop.

Element Materials

The pleated radial fin fiberglass element offers excellent chemical compatibility. The end caps are plated carbon steel with an O-ring seal. The standard cartridge can be used in service up to 200°F. Optional materials permit temperatures to 400°F.

Housing Design and Construction

Housings are designed and constructed in accordance with ASME Section VIII, Division I requirements for unfired pressure vessels. Models AGS-115 and larger are furnished with 1/4" NPT gauge connections on the inlet/outlet nozzles. AGS Models 160 thru 190 are equipped with three support legs. All models have a large sump areas for the collection of liquids. An optional ball valve and auto drain are available for each mode. Housings can be equipped with ΔP gauges, sight glasses, and float switches. Contact the factor for detail.

Standard filter housings are of carbon steel construction and may be modified to meet special application needs. The housings are also available in 304 and 316 stainless materials. High pressure designs up to 6000 PSIG are also available.

Filter Materials & Ratings

- Housings - Carbon Steel
 - AGS 110: 150 PSIG at 100°F. Max
 - AGS 115 and larger: 180 PSIG at 650°F. Max
- Closure Gasket
 - NEOPRENE*: 300°F. Max
- Standard Elements
 - All Models: 200°F. Max
 - Fiberglass media; .3 retention at 99% minimum efficiency

* DuPont registered trademark

AGS Series Specifications

Up to 180 PSIG Operating Pressure

Model No.	Conn.		Dimensions-Inches ¹					Housing Gasket Part No.	Element			Approx. Weight Lbs.
	Size	Style	A	B	D	E	F		Part No.	No. Req'd.	Total filter Area Sq. Ft.	
AGS 110-005 FT	1/2	FPT	3 5/8	7/8	12 3/4	4 5/8	10 3/4	40313	20560	1	1.40	7
AGS 110-007 FT	3/4	FPT	3 5/8	7/8	12 3/4	4 5/8	10 3/4	40313	20560	1	1.40	7
AGS 110-010 FT	1	FPT	3 5/8	7/8	12 3/4	4 5/8	10 3/4	40313	20560	1	1.40	7
AGS 115-015 MT	1 1/2	MPT	5 1/4	3	17	11	10	6003N03	20561	1	3.40	20
AGS 120-020 MT	2	MPT	6 1/4	3	19	12	12	6004N04	20562	1	4.40	30
AGS 130-030 MT	3	MPT	8 1/4	4 1/2	20	18	12	6005N04	20563	1	6.40	45
AGS 140-030 MT	3	MPT	8 1/4	4 1/2	27 1/4	18	17	6005N04	20564	1	7.70	50
AGS 150-040 MT	4	MPT	10 1/4	5 1/2	35 1/4	20	17	6006N04	20565	1	8.50	80
AGS 150-040 FL	4	FLG	10 1/4	5 1/2	35 1/4	20	17	6006N04	20565	1	8.50	90
AGS 160-060 FL	6	FLG	12 1/4	29 1/2	59	22 3/4	17	6007N03	20566	2	18.60	330
AGS 180-080 FL	8	FLG	16	31	77	26	17	6008N03	20567	3	41.90	434
AGS 190-100 FL	10	FLG	20	33 1/2	84	32	17	6009N03	20568	3	40.30	768

1. All dimensions are approximate.

- Standard filters are supplied with .3 micron fiberglass filter medium and a NEOPRENE* closure gasket (300° F). Contact your Conser representative for other available materials.
- Models AGS 110 have a maximum design of 150 psig at 100° F.
- Models AGS 115 thru 190 have 1/4" NPT plugged gauge connections.
- Models AGS 160 thru 190 have 1" drain and vent connections.
- Model AGS 160 has two (2) handles for closure removal.
- Models AGS 180 & 190 have a hinged closure with one (1) handle.
- Models AGS 160 thru 190 have three (3) leg supports with length of 18" from bottom of vessel to grade.
- Flanged end models have 150 lb ANSI, R.F. flanges.
- All models are available in 304 & 316 stainless steel; consult factory.

*NEOPRENE is a registered trademark.

Optional Automatic Drain Valve

For automatic drainage of the coalesced liquid without system shutdown. Drain valves are cast iron and float operated for wide variation in flow with a maximum capacity of 2 gpm. A shut off valve is also supplied to allow periodic service while the Filter/Separator remains in operation. Recommended for compressed air and inert gas applications only. Drain valves are supplied installed.

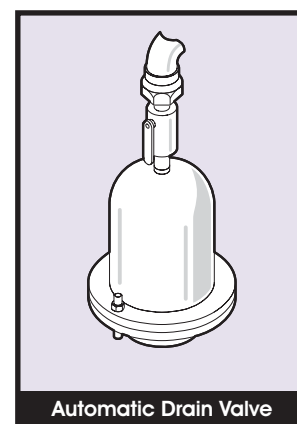

Automatic Drain Valve

Element Style for Models AGS 110 thru 190

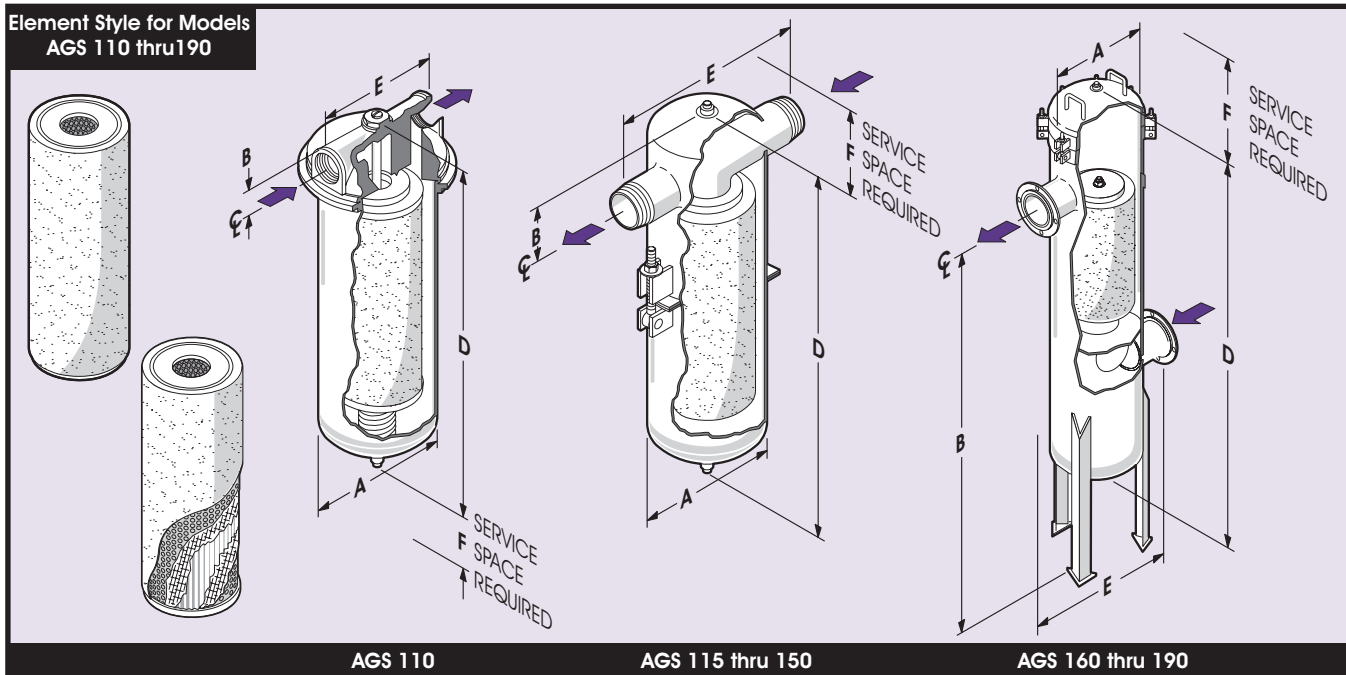

AGS 110

AGS 115 thru 150

AGS 160 thru 190

AGSH Series Specifications

Up to 285 PSIG Operating Pressure

Model No.	Conn.		Dimensions-Inches ¹				Housing Gasket Part No.	Element			Approx. Weight Lbs.
	Size	Style	A	D	E	F		Part No.	No. Req'd.	Total filter Area Sq. Ft.	
AGSH 110-005 MT	1/2	MPT	4.5	17.5	10	10	6015PSO	20560	1	1.4	60
AGSH 110-007 MT	3/4	MPT	4.5	17.5	10	10	6015PSO	20560	1	1.4	60
AGSH 110-010 MT	1	MPT	4.5	17.5	10	10	6015PSO	20560	1	1.4	60
AGSH 120-015 MT	1 1/2	MPT	6 5/8	25.5	13.5	12	6016PSO	20562	1	4.4	105
AGSH 120-020 FL	2	FLG	6 5/8	25.5	13.5	12	6016PSO	20562	1	4.4	105
AGSH 130-030 FL	3	FLG	8 5/8	33.5	18	12	6017PSO	20563	1	6.4	195
AGSH 140-030 FL	3	FLG	8 5/8	33.5	18	17	6017PSO	20564	1	7.7	195
AGSH 150-040 FL	4	FLG	10.75	43	20	17	6018PSO	20565	1	8.5	315
AGSH 160-060 FL	6	FLG	12.75	55	22.75	17	6019PSO	20566	2	18.6	465
AGSH 180-080 FL	8	FLG	16	88	26	17	6020PSO	20567	3	41.9	900
AGSH 190-100 FL	10	FLG	20	93	32	17	6021PSO	20568	3	40.3	1300

1. All dimensions are approximate.

- Standard gasket material is a CG style spiral wound, with 304 stainless steel compression ring and graphite filler.
- Models AGSH 120 thru 190 have 1/4" NPT plugged gauge connections.
- Models AGSH 130 thru 150 have two (2) handles for easy closure removal.
- Models AGS 160 thru 190 have a swing away cover device and one (1) handle.
- Models AGSH 130 thru 190 have three (3) leg supports with lengths of 18" from bottom of vessel to grade.
- Models AGSH 110 thru 150 have 1/2"NPT drain and vent connections. Models 160 thru 190 have 1" NPT drain and vent connections. Drain and vent connections are plugged 3000 lb. NPT couplings. Vent connections are drilled and tapped. .
- Flanges are 150 lb. ANSI, raised face slip on.

Optional Automatic Drain Valve

For automatic drainage of the coalesced liquid without system shutdown. Drain valves are cast iron and float operated for wide variation in flow with a maximum capacity of 2 gpm. A shut off valve is also supplied to allow periodic service while the Filter/Separator remains in operation. Recommended for compressed air and inert gas applications only. Drain valves are supplied installed.

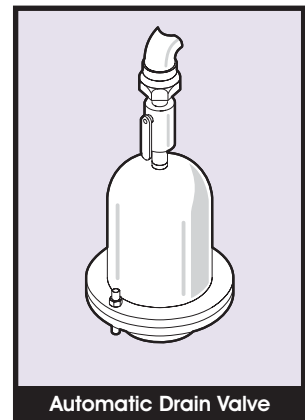

Automatic Drain Valve

Element Style for Models AGSH 110 thru 190

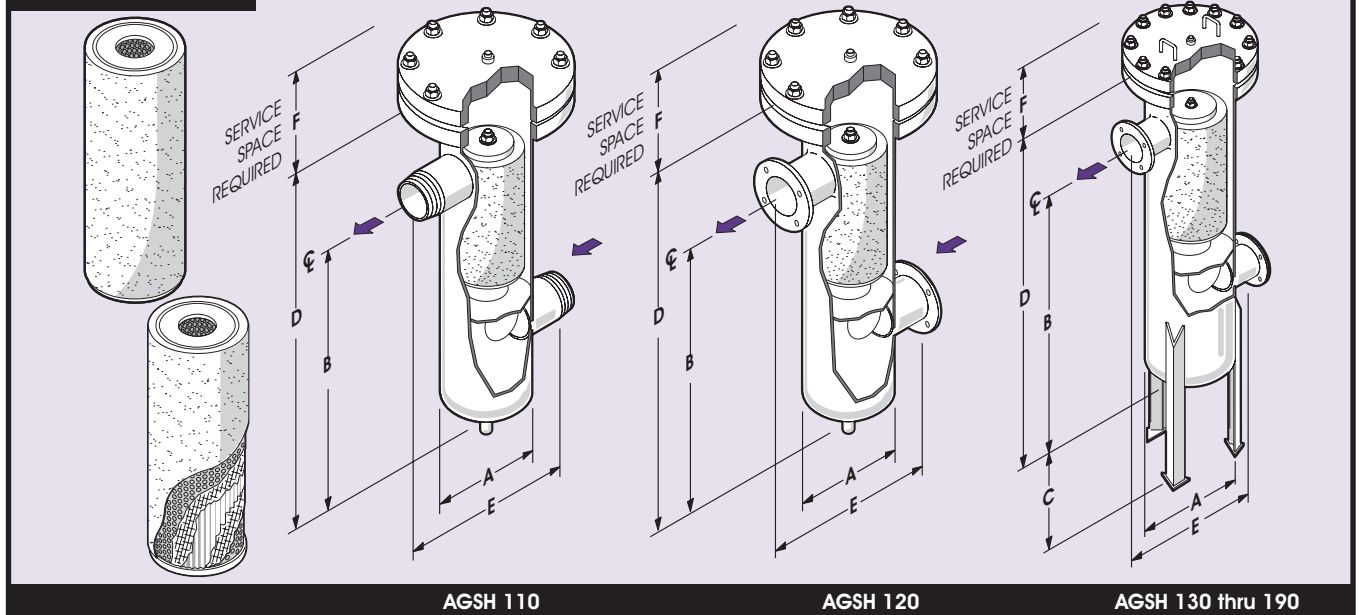

AGSHH Series Specifications

Up to 740 PSIG Operating Pressure

Model No.	Conn.		Dimensions-Inches ¹				Housing Gasket Part No.	Element			Approx. Weight Lbs.
	Size	Style	A	D	E	F		Part No.	No. Req'd.	Total filter Area Sq. Ft.	
AGSHH 110-005 MT	1/2	MPT	4.5	17.5	10	10	6034PSO	20560	1	1.4	82
AGSHH 110-007 MT	3/4	MPT	4.5	17.5	10	10	6034PSO	20560	1	1.4	82
AGSHH 110-010 MT	1	MPT	4.5	17.5	10	10	6034PSO	20560	1	1.4	82
AGSHH 120-015 MT	1 1/2	MPT	6 5/8	25.5	13.5	12	6035PSO	20562	1	4.4	150
AGSHH 120-020 FL	2	FLG	6 5/8	25.5	13.5	12	6035PSO	20562	1	4.4	150
AGSHH 130-030 FL	3	FLG	8 5/8	33.5	18	12	6036PSO	20563	1	6.4	295
AGSHH 140-030 FL	3	FLG	8 5/8	33.5	18	17	6036PSO	20564	1	7.7	295
AGSHH 150-040 FL	4	FLG	10.75	43	20	17	6037PSO	20565	1	8.5	500
AGSHH 160-060 FL	6	FLG	12.75	55	22.75	17	6038PSO	20566	2	18.6	850
AGSHH 180-080 FL	8	FLG	16	88	26	17	6039PSO	20567	3	41.9	1540
AGSHH 190-100 FL	10	FLG	20	93	32	17	6040PSO	20568	3	40.3	2310

1. All dimensions are approximate.

- Standard gasket material is a CG style spiral wound, with 304 stainless steel compression ring and graphite filler.
- Models AGSHH 120 thru 190 have 1/4" NPT plugged gauge connections.
- Models AGSHH 120 thru 150 have two (2) handles for easy closure removal.
- Models AGSHH 160 thru 190 have a swing away cover device, and one (1) handle.
- Models AGSHH 130 thru 190 have three (3) leg supports with lengths of 18" from bottom of vessel to grade.
- Models AGSHH 110 thru 150 have 1/2" NPT drain and vent connections. Models AGSHH 160 thru 190 have 1" NPT drain and vent connections. Drain and vent connections are plugged 3000 lb NPT couplings. Vent connections are drilled and tapped.
- All flanges are 300 lb ANSI, raised face slip on.

Optional Automatic Drain Valves and Liquid Level Switches

For automatic drainage of the coalesced liquid without system shutdown. Drain valves are available in a variety of materials including carbon steel, stainless steel, and other alloys. Contact the factory for information on valves, drains, and instrumentation that meet your application needs.

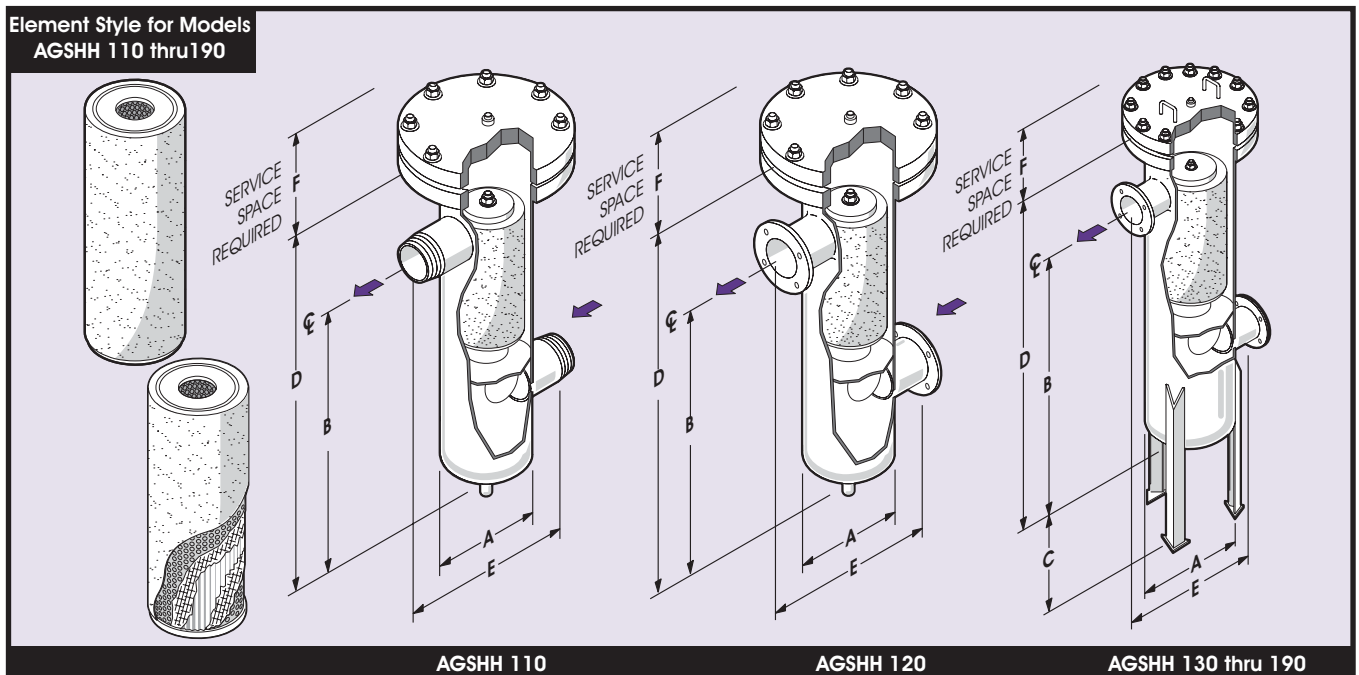

AGS Series Flow Rate Capability Charts¹

Capacity (SCFM) vs. Differential Pressure (psig), Air at 60° F²

Model No.	Operating Pressure (PSI)									MAX ΔP*
	20	50	80	100	120	150	200	250	300	PSIG
AGS 110-005 FT	94	174	255	309	363	443	578	712	847	1.9
AGS 110-007 FT	94	174	255	309	363	443	578	712	847	1.65
AGS 110-010 FT	94	174	255	309	363	443	578	712	847	1.6
AGS 115-015 MT	167	310	455	551	647	792	1032	1272	1512	4.3
AGS 120-020 FL	334	620	910	1103	1295	1583	2064	2544	3025	4.8
AGS 120-020 MT	334	620	910	1103	1295	1583	2064	2544	3025	4.8
AGS 130-030 FL	267	496	728	882	1036	1266	1651	2035	2420	2
AGS 130-030 MT	267	496	728	882	1036	1266	1651	2035	2420	2
AGS 140-030 FL	334	620	910	1103	1295	1583	2064	2544	3025	2.2
AGS 140-030 MT	334	620	910	1103	1295	1583	2064	2544	3025	2.2
AGS 150-040 FL	400	744	1092	1323	1554	1900	2477	3053	3630	1.9
AGS 150-040 MT	400	744	1092	1323	1554	1900	2477	3053	3630	1.9
AGS 160-060 FL	1134	2108	3094	3749	4403	5383	7017	8651	10285	2
AGS 180-080 FL	1400	2604	3822	4630	5439	6650	8670	10690	12705	1.75
AGS 190-180 FL	2800	5208	7644	9261	10880	13300	17335	21375	25410	2.3

Model No.	Operating Pressure (PSIG)									MAX ΔP*
	350	400	450	500	550	600	650	700	740	PSIG
AGS 110-005 FT	982	1116	1250	1385	1520	1655	1790	1925	2030	2.4
AGS 110-007 FT	982	1116	1250	1385	1520	1655	1790	1925	2030	1.8
AGS 110-010 FT	982	1116	1250	1385	1520	1655	1790	1925	2030	1.7
AGS 120-020 FL	3505	3990	4467	4950	5430	5910	6390	6870	7255	9.4
AGS 130-030 FL	2805	3190	3575	3960	4340	4730	5110	5500	5800	2.6
AGS 140-030 FL	3505	3990	4467	4950	5430	5910	6390	6870	7255	3.1
AGS 150-040 FL	4207	4785	5360	5940	6515	7090	7670	8245	8700	2.6
AGS 160-060 FL	11920	13550	15190	16820	18455	20090	21720	23360	24670	3.1
AGS 180-080 FL	14725	16740	18760	20780	22800	24820	26840	28850	30470	2.3
AGS 190-180 FL	29450	33480	37520	41560	45600	49630	53670	57710	60940	4.2

1. Values are based on actual test results or empirical calculations.
2. To determine proper filter sizing for gases other than air, multiply pressure drop by the correction factor for the appropriate gas from chart on back cover. For temperatures greater than 60° F, multiply pressure drop by the absolute temperature factor: $\frac{460 + [^{\circ}\text{F}]}{520}$
3. ΔP Values are representative of a clean, saturated element.

* Max delta P is calculated at the max recommended flow rate for a specific inlet pressure. The delta P for applications lower than the given flow rate will be lower than the max delta P indicated. If the max delta P required for your application is lower than that listed, please call the factory for the delta P calculation for your operating conditions

△ P Correction Factors (Specific Gravity Relative to Air)

Gas	Chem. Formula	Molecular Weight	△ P Correction Factor
Acetylene	C ₂ H ₂	26.00	0.897
Air	---	28.96	1.000
Ammonia	NH ₃	17.03	0.587
Argon	A	39.94	1.377
Bromine	Br ₂	159.83	5.519
Butane	C ₄ H ₁₀	58.12	2.007
Carbon Dioxide	CO ₂	44.01	1.520
Chlorine	Cl ₂	70.91	2.446
Ethane	C ₂ H ₆	30.07	1.039
Ethylene	C ₂ H ₄	28.05	0.967
Fluorine	F ₂	38.00	1.312
Helium	He	4.00	0.138
Hydrogen	H ₂	2.02	0.069
Methane	CH ₄	16.04	0.554
Natural Gas	---	---	0.610
Nitrogen	N ₂	28.02	0.967
Oxygen	O ₂	32.00	1.103
Propane	C ₃ H ₈	44.10	1.523
Propylene	C ₃ H ₆	42.08	1.453
Sulfur Dioxide	So ₂	64.07	2.208
Vinyl Chloride	CH ₂ CHCl	62.50	2.158

(Reference: Mechanical Engineers' Handbook by L.S. Marks, copyright May 1954; McGraw-Hill Book Co., Inc.)
For correction factors for gases other than those listed above, contact Graver.

Graver Technologies also makes:

- Air Intake Filters
- Air Intake Filter/Silencers
- Air/Gas Pressure Filters
- Vacuum Filters
- Liquid Filters/Strainers
- Smoke/Oil Mist Eliminators
- Filter Separators
- Special and Custom-Designed Filters and Filter Elements
- Lube Oil Filters and Filter Elements

Graver Technologies has representatives in major cities of the United States, Mexico and Canada. Representatives are also located in many other countries around the world.

Consler brand filters are manufactured in Honeoye Falls, NY. For more details about Consler brand filters contact your representative or Graver Technologies. Graver has a policy of continued product improvement and reserves the right to change specifications without notice.

Visit our web site at www.gravertech.com.

