

INDUSTRIAL FILTRATION PRODUCTS

CONSLER LGS SERIES COMPRESSED GAS SEPARATORS

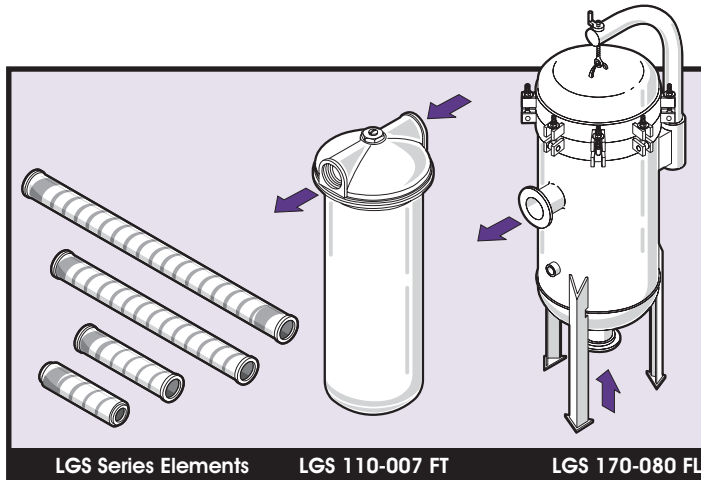

Features

- ASME Code designed and constructed
- High flow rate capabilities
- Low pressure drop and long element life
- High temperature capability
- Economical, replaceable cartridges
- Modified and custom designs available

Applications

- Effective separation of oil, water and other liquid aerosols from compressed air and gas lines.
- High efficiency removal of:
 - Dispersed liquids, 4 μ m & up, 99%
 - Solid particles, 1 μ m & up, 99%
- Use as a prefilter to an air dryer, increasing system efficiency and equipment service life.
- Gas pipeline applications, to protect equipment from liquid and solid contaminants.
- Ideal for satisfying original equip. mfr. specifications.

Element Design & Construction

The LGS Series filters offer a high efficiency coalescing style element. Each model employs one or more of these replaceable element cartridges which provide positive gasket sealing to prevent by-pass of unfiltered gases. Long filter life, low pressure drop, and efficient filtration and coalescing action are assured.

This coalescing action is simply a "gathering" of minute liquid particles or smaller droplets to form larger droplets. The small droplets that enter the inside of the element are intercepted or impinged by the filter media and extracted from the gas stream. The larger droplets once formed, drain off the outside of the element and fall by gravity to the sump area in the filter housing where a drain connection is provided for removing the coalesced liquid. The high efficiency element prevents re-entrainment of liquid downstream. The coalescing/

draining action continues at the same rate that new liquid enters the element, allowing long service life before element replacement is required.

The LGS Series filters are designed to handle liquid concentrations up to 1000 ppm and are capable of providing downstream air having less than 5 ppm of liquid. Dew point remains unaffected by the coalescing action.

Element Materials

Standard elements are composed of extremely fine borosilicate glass fibers with a resin binder, in a cylindrical, depth-type design. LGS Series elements may be used in service temperatures up to 200° F, and an optional element style permits high temperatures up to 400° F in continuous service and 450° F intermittently.

Standard elements are furnished with plated steel center core and end caps. Stainless steel and other materials are also available.

Housing Design and Construction

Housings are designed and constructed in accordance with ASME Code Sec. VIII Division I requirements for unfired pressure vessels (6 1/4" diameter and above). Models LGS 115 and above are available with "U" stamp registration and certification. All models can be quickly serviced without breaking pipe connections. Models LGS 120 and up are furnished with 1/4" NPT gauge connections on the inlet/outlet nozzles. Standard models LGS 130 and above are furnished with leg supports. Model LGS 160 has a hinged closure device, and Models LGS 170 and above are equipped with a davit lifting device for cover removal.

Standard filter housings may also be modified or customized to meet unique or special application needs. Typical design modifications include: special leg lengths, end connection types, inlet/outlet orientations, modified closure styles, and special controls and accessories. Special gasket and element materials will allow the filter vessel to be applied in service conditions up to its maximum design of 180 psig at 466° F.

Filter Materials and Ratings

- Housings - Carbon Steel
 - LGS 110: 150 psig at 100° F max.
 - LGS 115 & larger, threaded conns: 180 psig at 650° F max.
 - LGS 115 & larger, flange conns: 180 psig at 466° F max.
- Closure Gasket - NEOPRENE*; 300° F max.
- Standard Elements - Fiberglass media; 4 micron retention at 99% for dispersed liquids, 1 micron at 99% for solids; 250° F max; not cleanable. Optional elements up to 400°

*DuPont registered trademark.

LGS Series Specifications

Model No.	Conn.		Dimensions-Inches*						Housing Gasket Part No.	Element			Approx. Weight Lbs.
	Size	Style	A	B	C	D	E	F		Part No.	No Req'd.	Total filter Area Sq. Ft.	
LGS 110-005 FT	1/2	FPT	3 5/8	7/8	NA	12 3/4	4 5/8	10 3/4	40313	11305	1	.7	12
LGS 110-007 FT	3/4	FPT	3 5/8	7/8	NA	12 3/4	4 5/8	10 3/4	40313	11305	1	.7	12
LGS 110-010 FT	1	FPT	3 5/8	7/8	NA	12 3/4	4 5/8	10 3/4	40313	11305	1	.7	12
LGS 115-010 MT	1	MPT	6 1/4	8	NA	18	6	12	6004N04	11714	1	.8	70
LGS 120-015 MT	1 1/2	MPT	8 1/4	12	NA	20	8 1/8	12	6005N04	11714	3	2.3	80
LGS 130-015 MT	1 1/2	MPT	8 5/8	35	18	55	10	36	6024N03	10843	3	6.8	210
LGS 135-020 MT	2	MPT	10 1/4	14	18	35 1/4	10	24	6006N04	12853	4	6.1	90
LGS 140-020 MT	2	MPT	12 3/4	35	18	51 3/4	12	36	6007N03	10843	6	13.6	340
LGS 150-030 FL	3	FLG	16	35	18	57 1/8	15	36	6008N03	10843	13	29.5	500
LGS 150-040 FL	4	FLG	16	35	18	57 1/8	15	36	6008N03	10843	13	29.5	500
LGS 160-060 FL	6	FLG	20	35	22	58 3/4	19	36	6009N03	10843	19	43.1	700
LGS 170-080 FL	8	FLG	30	35	26 1/4	64 1/2	22	36	6012N03	10843	48	108.8	1200
LGS 180-100 FL	10	FLG	36	35	28	66 1/2	27	36	6013N03	10843	60	136.0	2100
LGS 190-120 FL	12	FLG	42	35	28	69 1/4	30	36	6017N03	10843	90	204.0	2900

*All dimensions are approximate.

- Standard filters are supplied with high efficiency fiberglass medium and neoprene gasket. Contact your Consler brand representative for other available materials.
- Models LGS 120 and above have 1/4" NPT plugged gauge connections.
- Models LGS 130 and above have three (3) leg supports with length of 18" from bottom of vessel to grade.
- Models LGS 140 thru 150 have two (2) handles for closure removal
- Model LGS 160 has a hinged cover with one (1) handle.
- Models 170 and above have a davit lift assembly for closure removal.
- Models LGS 115 thru 135 have 1/4" drain and vent connections.
- Models LGS 140 thru 160 have 1" drain and vent connections.
- Models LGS 170 thru 190 have 2" drain and 1" vent connections.

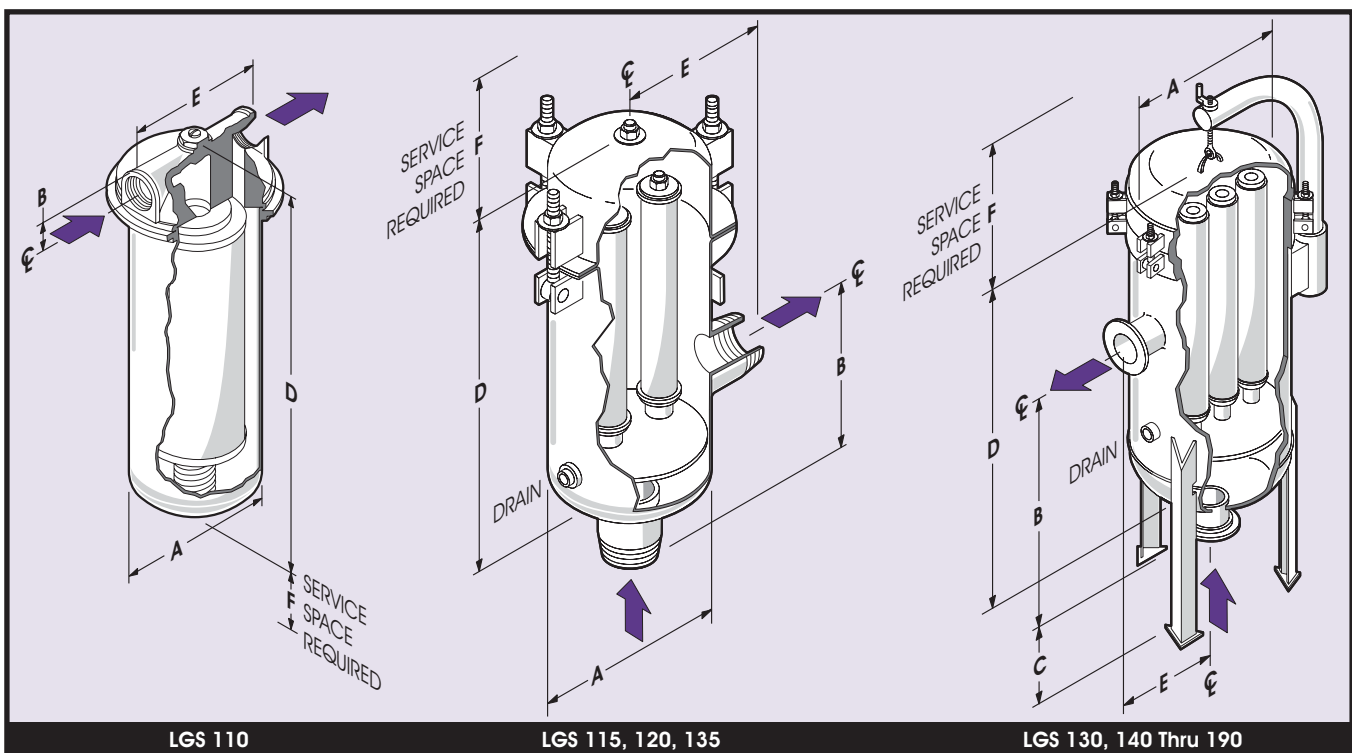

LGS Flow Rate Capatibility Charts¹

Capacity (SCFM) vs. Differential Pressure (psi)
At 60° F-Gas Specific Gravity 1.0 (Air)²

LGS Model	Inlet Pressure (psig)							
	10	20	40	60	80	100	125	150
LGS 110-005 FT	10	24	38	49	53	58	67	75
LGS 110-007 FT	16	39	62	78	85	93	106	125
LGS 110-010 FT	20	50	80	100	110	120	140	160
LGS 115-010 MT	22	55	88	110	121	132	154	176
LGS 120-015 MT	50	95	150	220	290	400	510	550
LGS 130-015 MT	100	204	280	350	495	600	730	825
LGS 135-020 MT	140	286	392	490	693	840	1020	1160
LGS 140-020 MT	230	408	560	750	990	1200	1460	1900
LGS 150-030 FL	380	650	900	1200	1560	2000	2400	2900
LGS 150-040 FL	540	884	1220	1660	2140	2600	3170	3800
LGS 160-060 FL	965	1495	2060	2760	3625	4400	5360	7300
LGS 170-080 FL	1430	3530	4860	6490	8570	10400	12670	14900
LGS 180-100 FL	1820	3900	5760	8500	10200	13600	16300	20000
LGS 190-120 FL	2400	5600	9450	12300	18900	20400	23600	29000

1. Values are based on actual test results or empirical calculations.

2. To determine proper filter sizing for gases other than air, multiply pressure drop by the correction factor for the appropriate gas from chart on back cover. For temperatures greater than 60°F, multiply pressure drop by the absolute temperature factor: $\frac{460 + (°F)}{520}$

Optional Automatic Drain Valve

For automatic drainage of the coalesced liquid without system shutdown. Drain valves are cast iron and float operated for wide variations in flow with a maximum capacity of 2 gpm. A shut off valve is also supplied to allow periodic service while the Filter/Separator remains in operation. Recommended for compressed air and inert gas applications only. Drain valves are supplied installed.

